

## MODIFICATION AT SIDE ENTRY PITS FOR TYPE SM2

-ONLY TO BE USED IN LOW RISK LOCATIONS WHERE CHANNEL GRATE WILL NOT WORK (REFER TO S410)

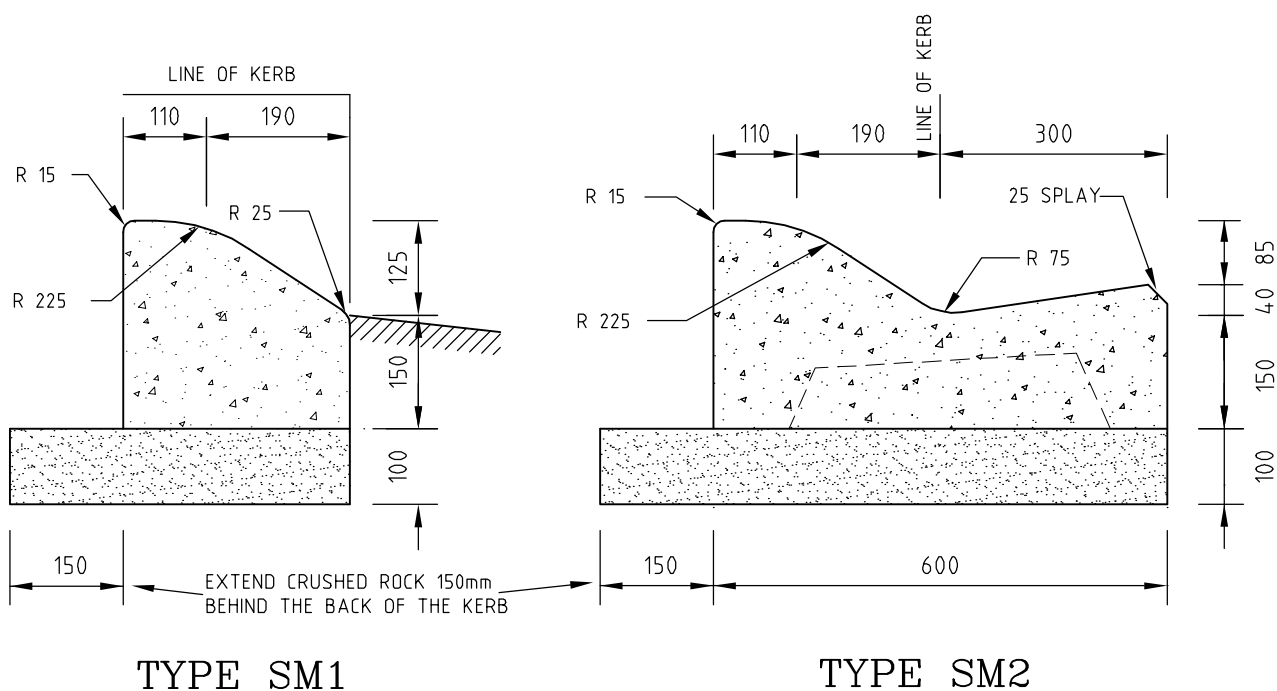

### NOTES:

ALL DIMENSIONS ARE IN MILLIMETRES UNLESS OTHERWISE SHOWN. CONCRETE STRENGTH SHALL BE 32 MPA MIN AT 28 DAYS. BEDDING SHALL CONSIST OF A MIN. 100mm COMPACTED DEPTH OF CLASS 2 3% CEMENT STABILISED CRUSHED ROCK 20mm NOMINAL TO FINAL LEVEL & GRADE UNLESS OTHERWISE SPECIFIED

**KINGSTON CITY COUNCIL**  
STANDARD DRAWING

DRG. NO. **S101**

ISSUE DATE: 22/03/12

SEMI - MOUNTABLE KERB AND CHANNEL TYPE SM1 AND SM2  
MODIFICATION AT SIDE ENTRY PITS FOR TYPE SM2

STANDARD DRAWING ISSUE  
CURRENT AT TIME OF  
CONSTRUCTION MUST BE USED

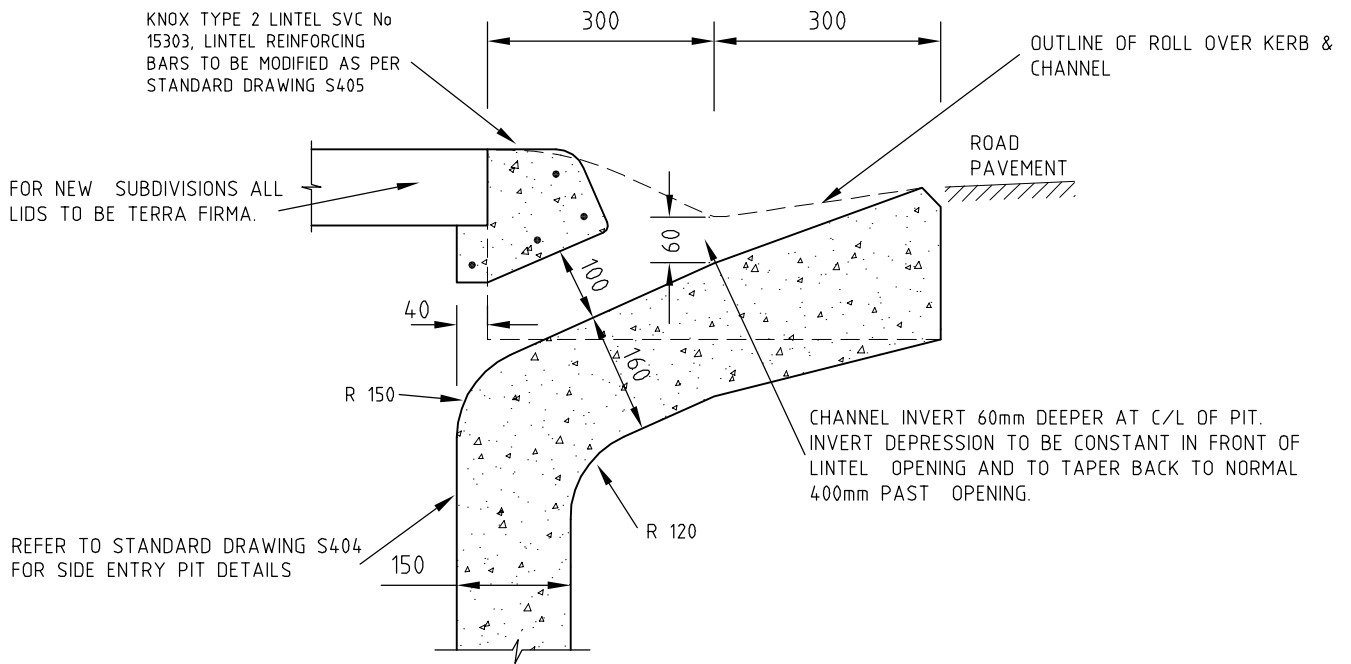

## ROLL OVER KERB MODIFICATION AT SIDE ENTRY PITS

-ONLY TO BE USED IN LOW RISK LOCATIONS WHERE CHANNEL GRATE WILL NOT WORK (REFER TO S410)

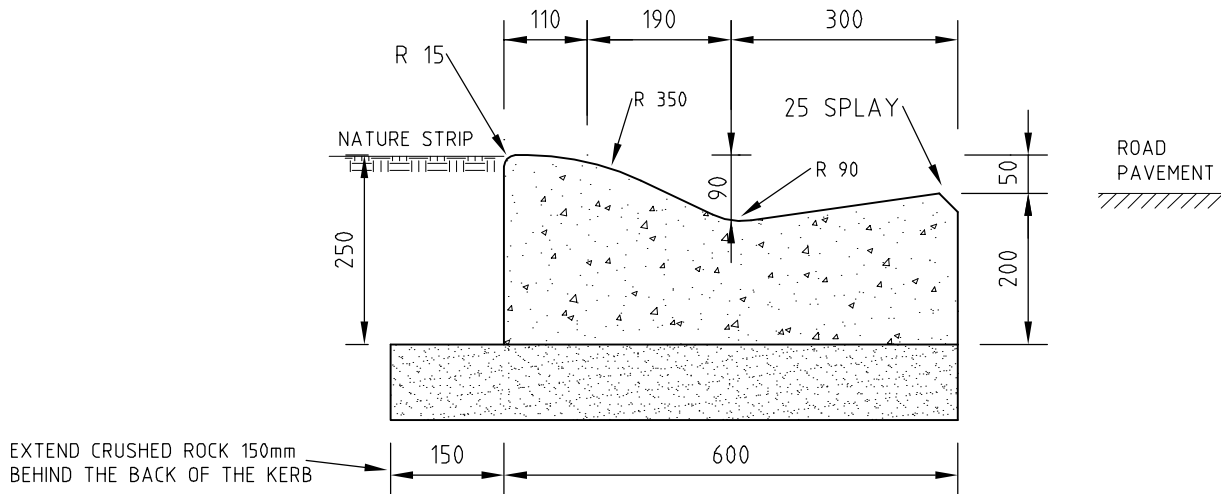

## ROLL OVER KERB AND CHANNEL (TYPE R1)

-SEE S105 FOR OUTFALL ROLL OVER KERB AND CHANNEL (TYPE R2)

**NOTES:**

ALL DIMENSIONS ARE IN MILLIMETRES UNLESS OTHERWISE SHOWN. CONCRETE STRENGTH SHALL BE 32 MPA MIN AT 28 DAYS. BEDDING SHALL CONSIST OF A MIN. 100mm COMPACTED DEPTH OF CLASS 2 3% CEMENT STABILISED CRUSHED ROCK 20mm NOMINAL TO FINAL LEVEL & GRADE UNLESS OTHERWISE SPECIFIED

**KINGSTON CITY COUNCIL  
STANDARD DRAWING**

DRG. NO. **S102**

ISSUE DATE: 22/03/12

ROLL OVER KERB AND CHANNEL TYPE R1  
MODIFICATION AT SIDE ENTRY PITS

STANDARD DRAWING ISSUE  
CURRENT AT TIME OF  
CONSTRUCTION MUST BE USED

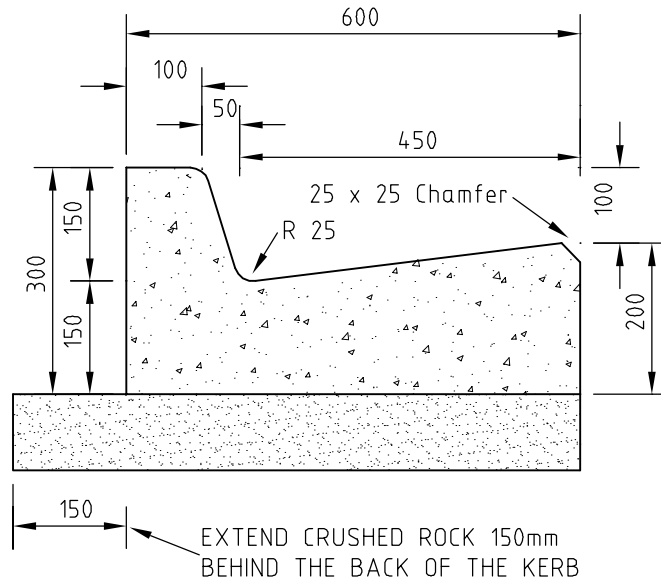

**KERB AND CHANNEL (TYPE BK1)**

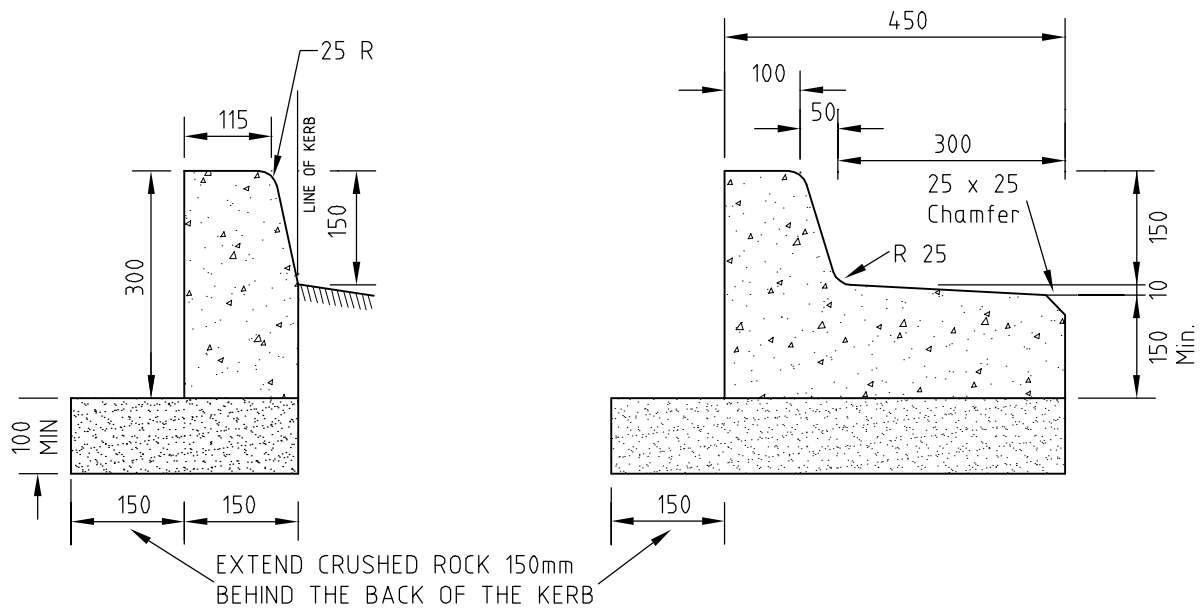

**BARRIER KERB (TYPE BK2)**

**KERB AND CHANNEL (TYPE BK3)**

OUTFALL TRAY

**NOTES:**

ALL DIMENSIONS ARE IN MILLIMETRES UNLESS OTHERWISE SHOWN. CONCRETE STRENGTH SHALL BE 32 MPA MIN AT 28 DAYS. BEDDING SHALL CONSIST OF A MIN. 100mm COMPACTED DEPTH OF CLASS 2, 3% CEMENT STABILISED CRUSHED ROCK 20mm NOMINAL TO FINAL LEVEL & GRADE UNLESS OTHERWISE SPECIFIED

**KINGSTON CITY COUNCIL  
STANDARD DRAWING**

DRG. NO. **S103**

ISSUE DATE: 22/03/12

KERB AND CHANNEL TYPE BK1, BK3  
AND KERB TYPE BK2

STANDARD DRAWING ISSUE  
CURRENT AT TIME OF  
CONSTRUCTION MUST BE USED

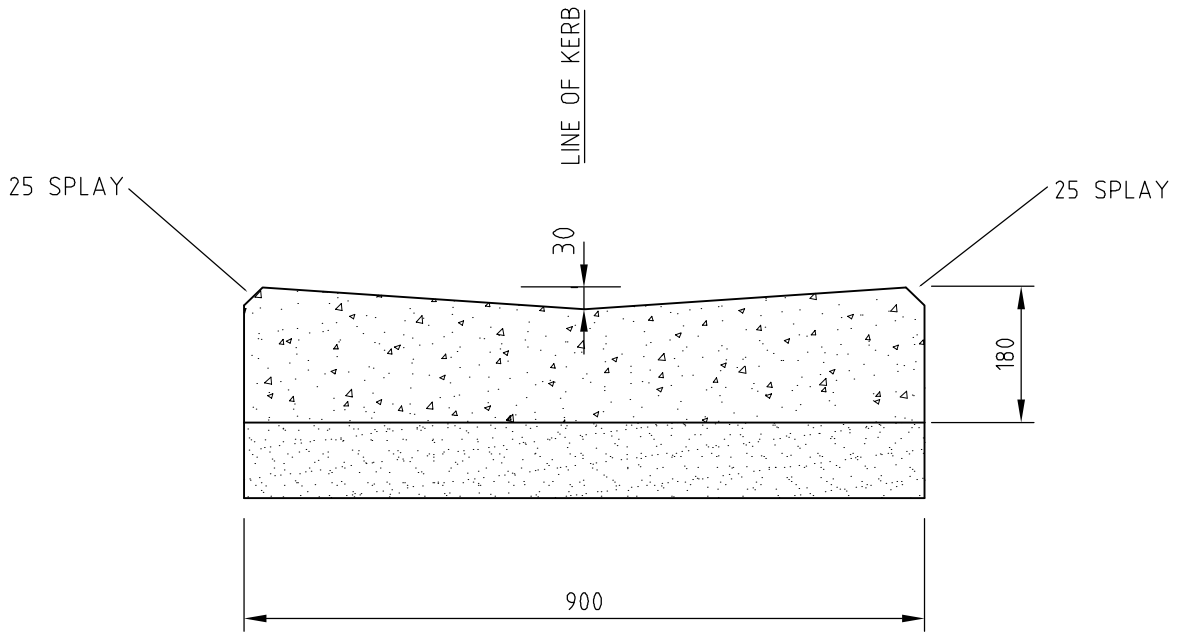

FLOOD DISH (TYPE FD1)

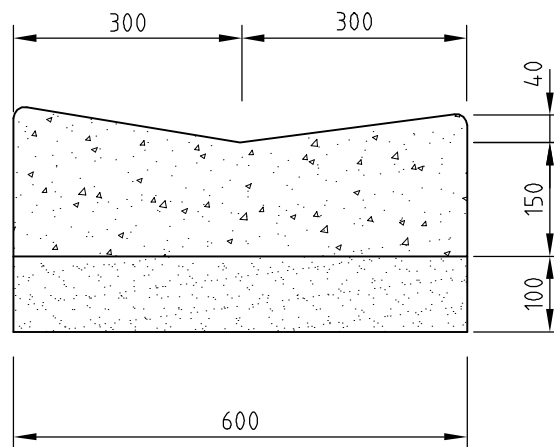

FLOOD DISH (TYPE FD2)

NOTES:

ALL DIMENSIONS ARE IN MILLIMETRES UNLESS OTHERWISE SHOWN. CONCRETE STRENGTH SHALL BE 32 MPA MIN AT 28 DAYS. BEDDING SHALL CONSIST OF A MIN. 100 mm COMPACTED DEPTH OF CLASS 2 3% CEMENT STABILISED CRUSHED ROCK 20mm NOMINAL TO FINAL LEVEL & GRADE UNLESS OTHERWISE SPECIFIED.

KINGSTON CITY COUNCIL  
STANDARD DRAWING

DRG. NO. S104

ISSUE DATE: 22/03/12

PROFILE OF CONCRETE FLOOD DISH

STANDARD DRAWING ISSUE  
CURRENT AT TIME OF  
CONSTRUCTION MUST BE USED

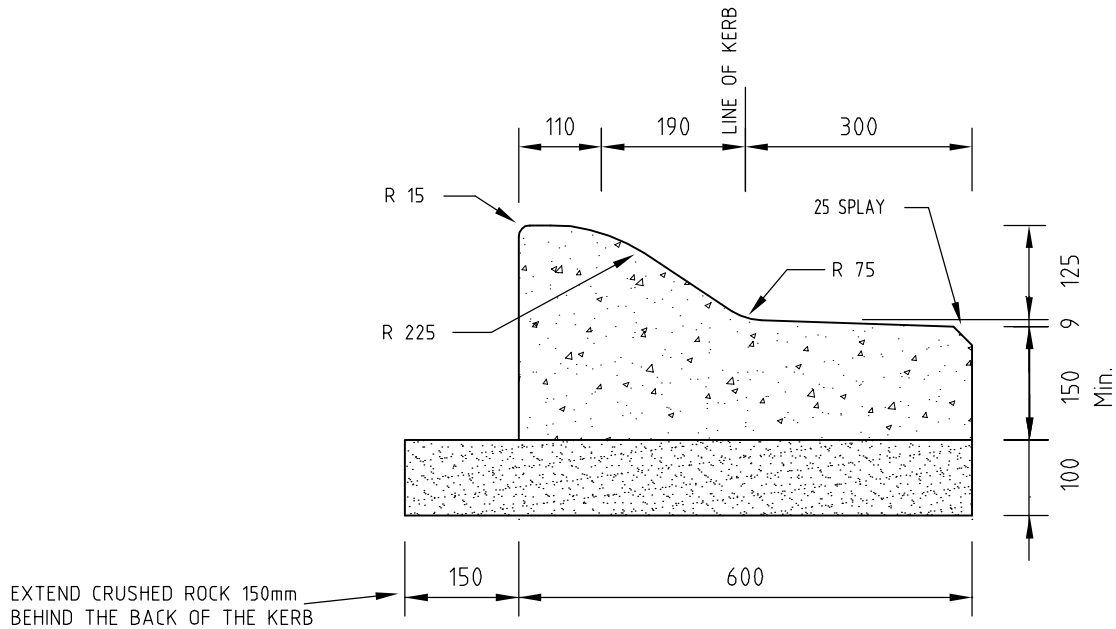

**TYPE SM3**

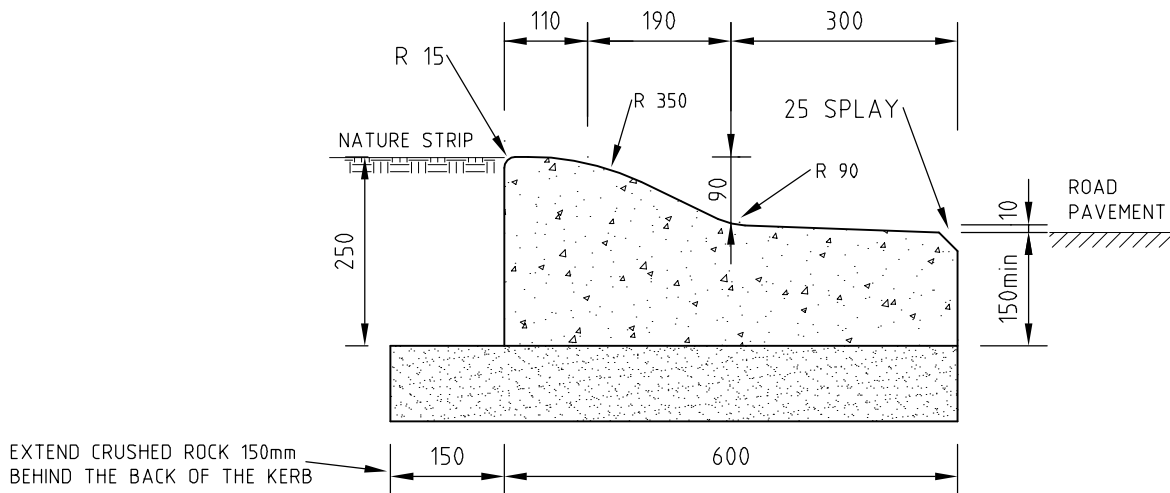

**OUTFALL ROLLOVER KERB AND CHANNEL TYPE R2**

**NOTES:**

ALL DIMENSIONS ARE IN MILLIMETRES UNLESS OTHERWISE SHOWN. CONCRETE STRENGTH SHALL BE 32 MPA MIN AT 28 DAYS. BEDDING SHALL CONSIST OF A MIN. 100mm COMPACTED DEPTH OF CLASS 2 3% CEMENT STABILISED CRUSHED ROCK 20mm NOMINAL TO FINAL LEVEL & GRADE UNLESS OTHERWISE SPECIFIED

**KINGSTON CITY COUNCIL  
STANDARD DRAWING**

DRG. NO. **S105**

ISSUE DATE: 22/03/12

SEMI - MOUNTABLE KERB AND CHANNEL TYPE SM3  
OUTFALL ROLL OVER KERB AND CHANNEL TYPE R2

STANDARD DRAWING ISSUE  
CURRENT AT TIME OF  
CONSTRUCTION MUST BE USED